

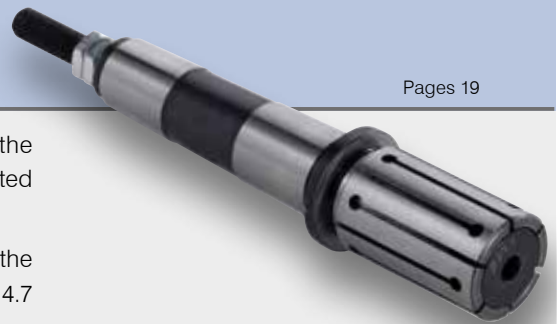

- Automatic or manual actuation
- Morse taper mounting

# TMCMT

Pages 19



TMCMT mandrels are similar to TMCM but they clamp the workpiece by the operation of a driving screw on the back face of the mandrel, which is connected to the machine's drawbar.

This type offers an expansibility of 1 to 2 mm depending on the diameter of the expanding sleeve, and can clamp workpieces with diameters ranging from 14.7 to 82.7 mm.

### Clamping takes place as follows:

Since the workpiece can be clamped and unclamped automatically by operating this driving screw, workpiece changing time is reduced and operating convenience is greatly improved.

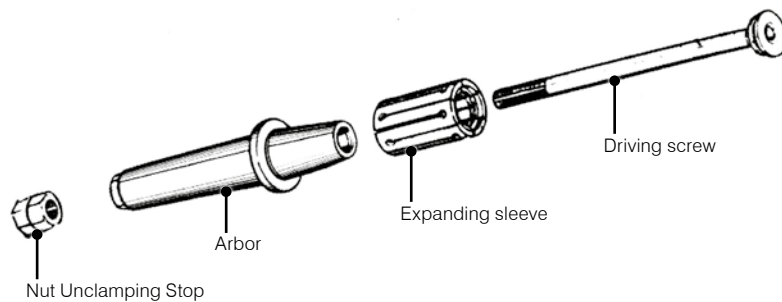

When placing an order for arbors and expanding sleeves, please provide the order codes individually. They will be shipped without being assembled.

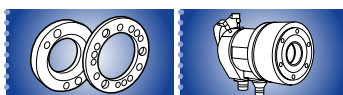

# Morse taper expanding Mandrels

■ Clamping range Ø14,7 to 82,7 mm



tobler

# TMCMT

Expanding Mandrels TOBLER



## ■ ARBOR

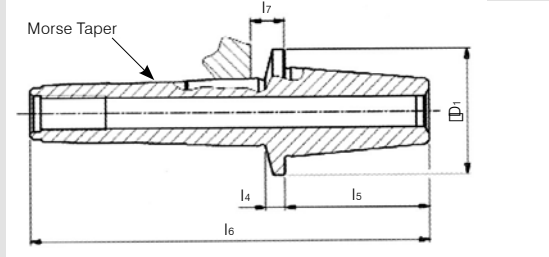

## ■ EXPANDING SLEEVE (1)

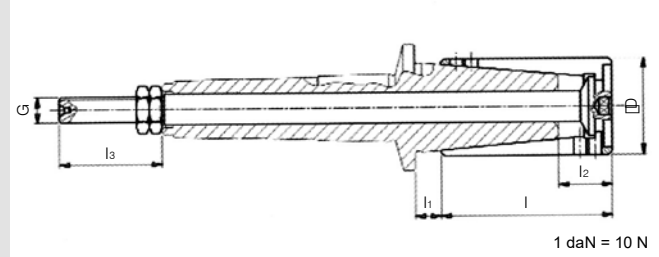

Subject to technical changes.  
For more detailed information, please ask our customer service.

Order Code	Workpiece Diameter Range	Morse Taper N°	D1	l4	l5	l6	l7	kg
TMCMT-1x4	14,7 - 19,7	4	32		29,0	138,0	6,5	0,530
TMCMT-2x4	19,7 - 24,7	4	32		32,0	141,0	6,5	0,530
TMCMT-3x4	24,7 - 29,7	4	33	7	38,0	154,0	13,5	0,537
TMCMT-4x4	29,7 - 34,7	4	38	7	41,0	157,0	13,5	0,636
TMCMT-5x4	34,7 - 39,7	4	43	8	50,0	167,0	14,5	0,710
TMCMT-6x4	39,7 - 44,7	4	48	9	50,0	168,0	15,5	0,755
TMCMT-7x4	44,7 - 54,7	4	58	9	67,0	185,0	15,5	1,015
TMCMT-8x4	54,7 - 64,7	4	68	12	75,0	196,0	18,5	1,488
TMCMT-9x4	64,7 - 82,7	4	86	14	85,5	208,5	20,5	2,210

When placing an order, please specify the order code and quantity. Dimensions (mm)  
 Ask for quotations for price and delivery of TMCMT-8 and TMCMT-9

Order Code	D	l	l1	l2 <sup>2)</sup>	l3	G	Expansibility	Maximum Force on Driving Screw (daN)	Maximum Torque Nm
TMCMT147-1x4	14,7								
TMCMT157-1x4	15,7	35	6,5	12,5	26	M6	1	700	15
TMCMT167-1x4	16,7								
TMCMT177-1x4	17,7								
TMCMT187-1x4	18,7								
TMCMT197-2x4	19,7								
TMCMT207-2x4	20,7	40	6,5	14,5	28	M8	1	900	35
TMCMT217-2x4	21,7								
TMCMT227-2x4	22,7								
TMCMT237-2x4	23,7								
TMCMT247-3x4	24,7								
TMCMT257-3x4	25,7	46	6,5	14,5	31	M10	1	1.200	75
TMCMT267-3x4	26,7								
TMCMT277-3x4	27,7								
TMCMT287-3x4	28,7								
TMCMT297-4x4	29,7								
TMCMT307-4x4	30,7	50	6,5	15,5	31	M10	1	1.200	100
TMCMT317-4x4	31,7								
TMCMT327-4x4	32,7								
TMCMT337-4x4	33,7								
TMCMT347-5x4	34,7								
TMCMT357-5x4	35,7	60	6,5	16,5	36	M12	1	1.500	120
TMCMT367-5x4	36,7								
TMCMT377-5x4	37,7								
TMCMT387-5x4	38,7								
TMCMT397-6x4	39,7								
TMCMT407-6x4	40,7	60	6,5	16,5	36	M12	1	1.500	150
TMCMT417-6x4	41,7								
TMCMT427-6x4	42,7								
TMCMT437-6x4	43,7								
TMCMT447-7x4	44,7								
TMCMT467-7x4	46,7	80	12,0	25,0	36	M12	2	2.000	200
TMCMT487-7x4	48,7								
TMCMT497-7x4	49,7								
TMCMT507-7x4	50,7								
TMCMT527-7x4	52,7								
TMCMT547-8x4	54,7								
TMCMT567-8x4	56,7	90	12,0	27,0	36	M14	2	2.000	250
TMCMT587-8x4	58,7								
TMCMT597-8x4	59,7								
TMCMT607-8x4	60,7								
TMCMT627-8x4	62,7								
TMCMT647-9x4	64,7								
TMCMT667-9x4	66,7	100	12,0	26,5	36	M14	2	2.500	275
TMCMT687-9x4	68,7								
TMCMT697-9x4	69,7								
TMCMT707-9x4	70,7								
TMCMT727-9x4	72,7								
TMCMT747-9x4	74,7								
TMCMT767-9x4	76,7								
TMCMT787-9x4	78,7								
TMCMT807-9x4	80,7								

1) The expanding sleeve is shipped with the driving screw fitted. Dimensions (mm)  
 2) Do not clamp in the range l2.  
 When placing an order, please specify the order code and quantity.